



Installation Instructions

Lift Connect® Access Manager

***Refer to Models Included
section for model and serial
number information***

Original Instructions
First Edition
First Printing
Part No. 1306774GT

Introduction



Observe and Obey:

- Immediately tag and remove from service a damaged or malfunctioning machine.
- Repair any machine damage or malfunction before operating the machine.

Before Starting Installation:

- Read, understand and obey the safety rules and operating instructions in the appropriate operator's manual.
- Be sure that all necessary tools and parts are available and ready for use.
- Read this procedure completely and adhere to the instructions. Attempting shortcuts may produce hazardous conditions.

Note: These installation instructions only apply to the Genie models and serial number ranges listed within this document.

If you have any further questions regarding these instructions or need assistance, please contact Genie Product Support at one of the following telephone numbers:

United States:	+ 800 536 1800
Canada:	+ 425 881 1800
Europe: UK	+ 44 1476 584 333
France	+ 33 237 260 986
Germany	+ 49 421 3770 9890
Iberica	+ 34 900 808 110
Italy	+ 39 075 941 8184
Scandinavia	+ 44 1476 584 333
Other locations	+ 31 165 51 93 22
Middle East:	+ 97 143 990 381 or + 97 150 459 7937
Australia:	+ 61 7 3456 4444
Brazil:	+ 0 800 031 0100
South America - other locations	+ 56 9 6431 2110
All other locations	+ 1 425-881 1800

Copyright © 2021 by Terex Corporation

First Edition: First Printing, October 2021

Genie, "S", "Z" and "ZX" are registered trademarks of Terex South Dakota, Inc. in the U.S.A. and many other countries.

"SX" and "XC" are trademarks of Terex South Dakota, Inc.

"TraX" is a trademark of Terex South Dakota, Inc.



Introduction

Models Included

Model	From serial number
S-40 XC S-40 HF S-40 TraX	S40XCH-101
S-45 XC S-45 HF S-45 TraX	S45XCD-101 S45XCH-101
S-60 XC S-60 HF S-60 TraX	S60XCH-45001
S-65 XC S-65 HF S-65 TraX	S65XCD-101 S65XCM-101 S65XCH-45001
S-80 XC S-80 HF	S80XCH-101
S-85 XC S-85 HF	S85XCD-101 S85XCH-101
S-60 J S-80 J	S60JD-101 S60JH-101 S80JD-101 S80JH-101
SX-105 XC	SX105D-174 to SX105D-783 SX105D-1110
SX-125 XC	SX125D-101 to SX125D-821 SX105D-928
SX-135XC	SX135H-101
SX-150	SX15015H-101 to SX15016H-499 SX150H-500
SX-180	SX18014H-101 to SX18016H-599 SX180H-600
Z-60 DC Z-60FE	Z6016N-101 to Z6016N-599 Z60N700 to Z60N-700 Z60H-701
ZX-135/70	ZX13515-2646 to ZX13516-2789 ZX13516H-2790 to ZX13516H-3199 ZX135H-3200

Tools Required:

9/32 inch wrench
 3/32 inch hex key
 Small flathead screwdriver
 Flathead screwdriver
 Wire crimper
 Wire stripper
 Cable tie gun or wire cutters
 11/64 inch / 4.4 mm drill bit
 Step drill bit, 1 inch / 25 mm
 Drill motor
 Mild cleaning solvent
 Soft clean cloth

Introduction

Components of Kit 1311011GT

**S-40/45XC, S-60J, S-80J, S-60/65XC,
S-80/85XC, Z-60 DC/FE**

Description	Genie part number	Qty.
Cable tie, 4 inch, black	21121GT	6
Flat washer, M4, DIN125, ZAB	825357GT	4
Adjustable adhesive wire clamp	1273629GT	6
Nylock nut, M4-0.7, DIN985, 8, ZAB	1283019GT	2
Access management keypad	1296895GT	1
Access management harness	1296897GT	1
Screw, BHC, M4-0.7 x 35, 10.9, ZAB	1300832GT	2
Access manager user guide	1312446GT	1
Installation instructions	1306774GT	1

Components of Kit 1311012GT

SX-105/125/135XC, SX-150/180, ZX-135/70

Description	Genie part number	Qty.
Cable tie, 4 inch, black	21121GT	6
Flat washer, M4, DIN125, ZAB	825357GT	4
Adjustable adhesive wire clamp	1273629GT	6
Nylock nut, M4-0.7, DIN985, 8, ZAB	1283019GT	2
Access management keypad	1296895GT	1
Access management harness	1296896GT	1
Screw, BHC, M4-0.7 x 35, 10.9, ZAB	1300832GT	2
Access manager user guide	1312446GT	1
Installation instructions	1306774GT	1

Procedure

Note: Perform this procedure on a firm, level surface with the machine in the stowed position.

- 1 Turn the key switch to the off position and push in the red Emergency Stop button to the off position at the ground controls.
- 2 Working at the ground control side, mark the points on the cover to drill holes.

Note: Refer to the *Drilling Diagram* section that is appropriate for your machine.

- 3 Drill the center hole using 1 inch / 25 mm step drill bit suitable for drilling fiberglass.
- 4 Using an 11/64 inch / 4,4 mm drill bit, drill the remaining two holes.

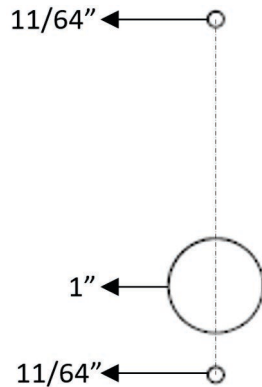

- 5 Mount the keypad using the provided retaining fasteners.

Genie part numbers 1296895GT, 1300832GT 1283019GT, 825357GT.

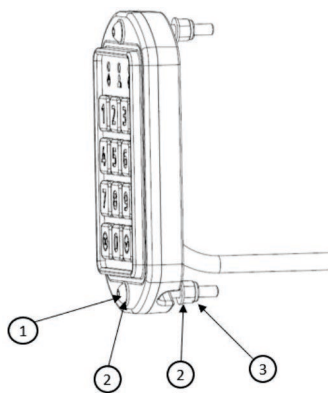

- 1 screw
- 2 flat washer
- 3 nylock nut

- 6 Using a mild cleaning solvent, clean the inner surface of the cover and mount the adhesive wire clamps to the locations shown.

Genie part number 1273629GT.

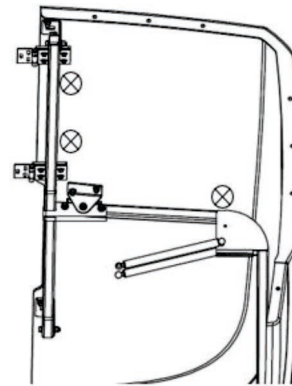
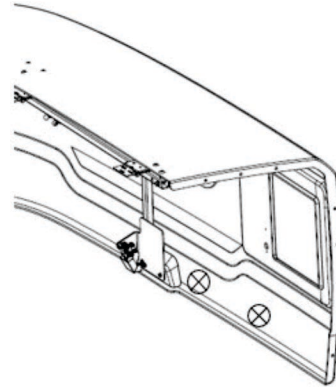

⊗ example of adhesive wire clamp locations

- 7 Route the keypad harness through the center hole and along the cover support.

Procedure

- Secure the harness to the cover support and the adhesive wire clamps using the provided cable ties.

Genie part number 21121GT.

Note: Verify the harness does not bind or get caught on surrounding components as the door opens and closes.

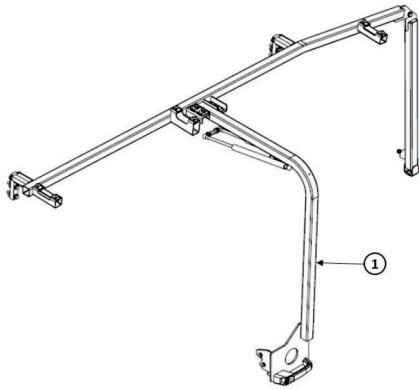

1 cover support

- Working at the ground control box side, disconnect the telematics module from gateway harness.
- Connect the telematics module harness to the provided access management harness.

Genie part number 1296897GT.

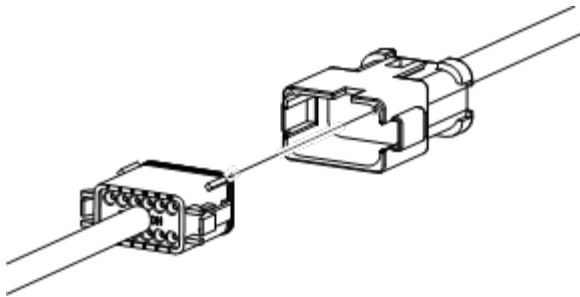

- Connect the 12 pin loose end of the harness to the gateway harness connector.
- Route the 5 pin connector along the cover support to the access manager keypad harness and secure it with cable ties.
Genie part number 21121GT.
- Connect the harness to the keypad.
- Put the Access Manager user guide in the manual storage box located on the machine.
Genie part number 1312446GT.

Procedure

Updating the Machine Software

Note: Not all machines will require a software update.

- 1 Verify the software revision on your machine.
- 2 Turn the key switch to ground control and pull out the Red Emergency Stop button to the on position.
- 3 Read and record the software revision displayed on the LCD screen.

Software Version: _____

Note: Refer to the following chart to determine if the machine software requires updating.

Model	Software Version
S-40/45XC	S-60J
S-60/65XC	S-80J
S-80/85XC	1.7.0
SX-105XC	V203
SX-125XC	V202
SX-135XC	V202
SX-150	V202
SX-180	V302
Z-60 DC/FE	H
ZX-135/70	V503

Note: Models with a software version listed is the minimum requirement to support Access Manager and does not require an immediate software update.

▲ Genie recommends updating the machine software to receive the latest updates and features available. Refer to the Genie Firmware website.

Note: Models with a lower revision level must update the system software. Refer to *Firmware Site Download*.

Firmware Site Download

- 1 Access the firmware website address below:
<https://www.genielift.com/en/support/firmware>
- 2 From the drop-down menu, select the model that is appropriate for your machine.
- 3 Update the software using the appropriate instructions for your machine.

Access Manager Activation

- 1 Navigate to the Options menu on the machine and verify Lift Connect is selected.
- 2 To complete activation of your Access Manager keypad please contact the Lift Connect team.

[mailto:
AWP.LiftConnectSubscriptions@terex.com](mailto:AWP.LiftConnectSubscriptions@terex.com)

Drilling Diagram

Note: Units of measurement are in inches, [mm] are in millimeters.

S-60 J, S-80 J, S-60/65 XC, S-80/85 XC

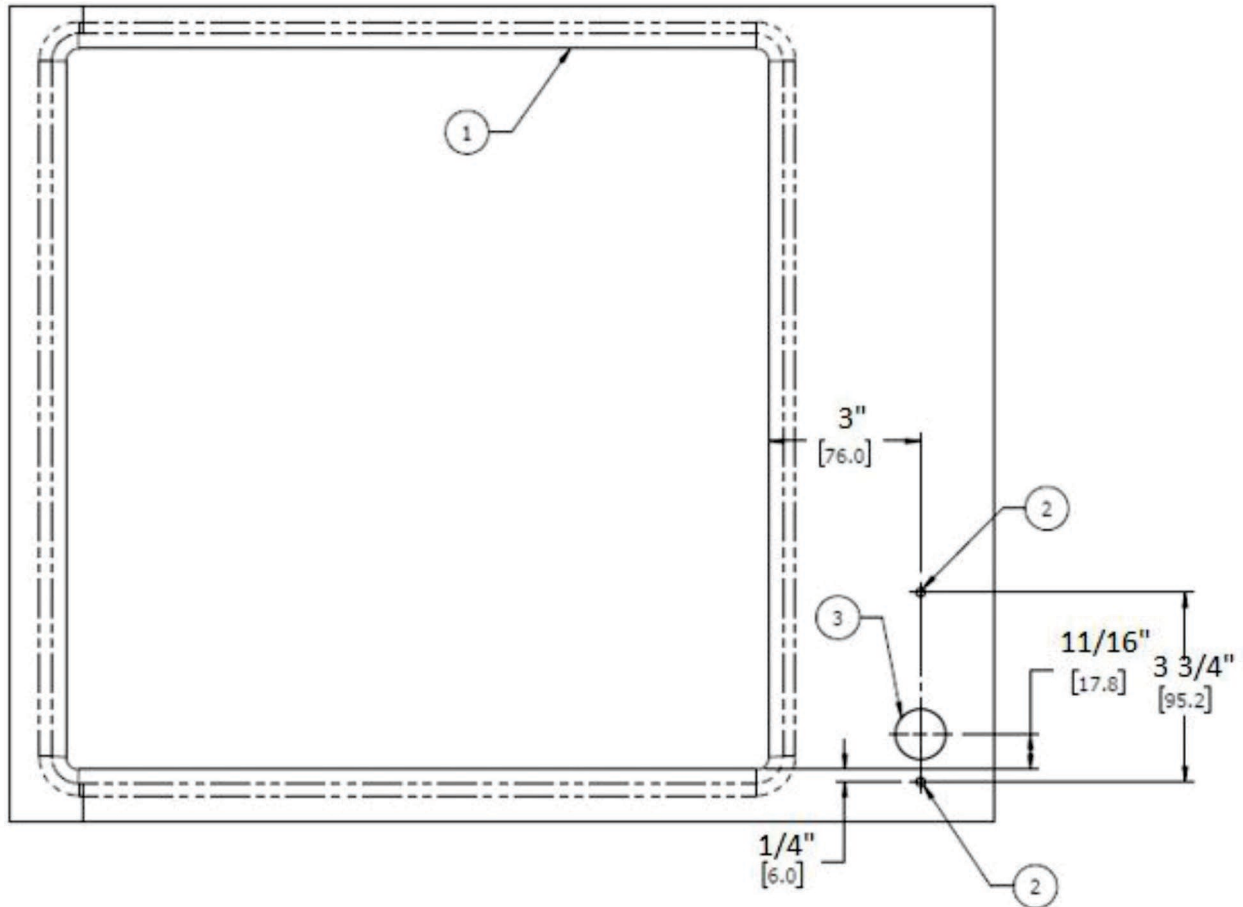

- 1 ground control turntable cover
- 2 keypad mounting holes, 11/64 inch / 4.4 mm drill bit
- 3 keypad harness hole, 1 inch / 25 mm step drill bit

Drilling Diagram

Note: Units of measurement are in inches, [mm] are in millimeters.

S-40/45 XC

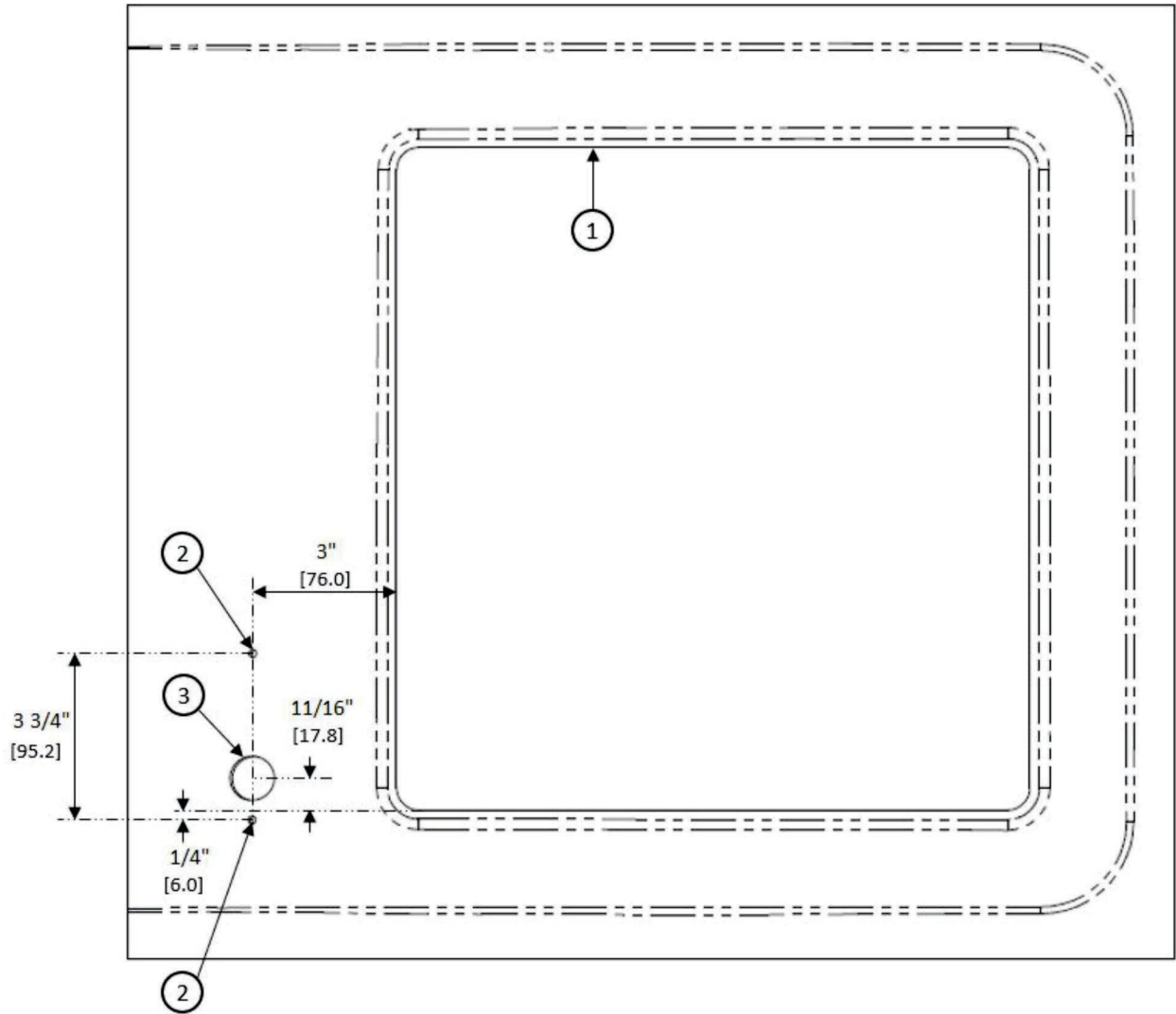

- 1 ground control turntable cover
- 2 keypad mounting holes, 11/64 inch / 4.4 mm drill bit
- 3 keypad harness hole, 1 inch / 25 mm step drill bit

Drilling Diagram

Note: Units of measurement are in inches, [mm] are in millimeters.

SX-105 XC, SX-125 XC, SX-135 XC, SX-180, SX-150, ZX-135/70

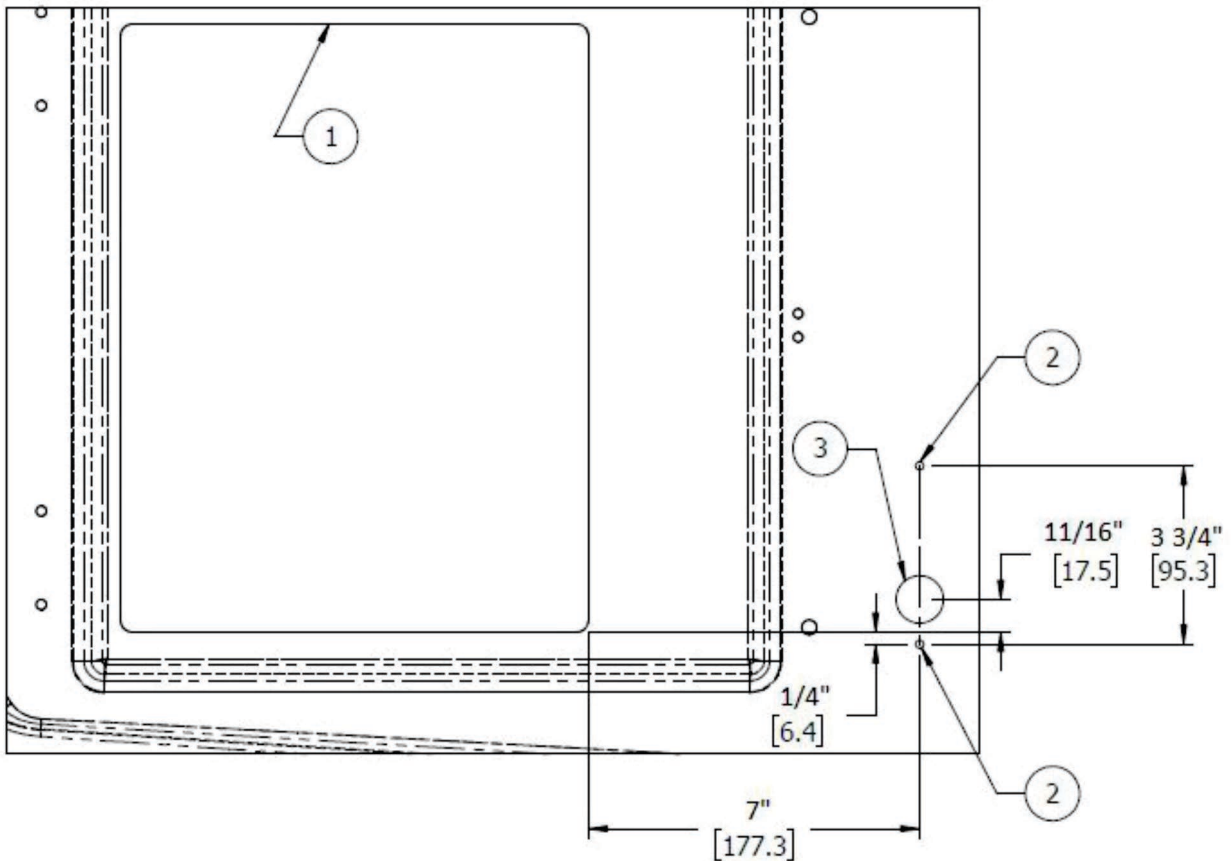

- 1 ground control turntable cover
- 2 keypad mounting holes, 11/64 inch / 4.4 mm drill bit
- 3 keypad harness hole, 1 inch / 25 mm step drill bit

Drilling Diagram

Note: Units of measurement are in inches, [mm] are in millimeters.

Z-60 DC, Z-60 FE

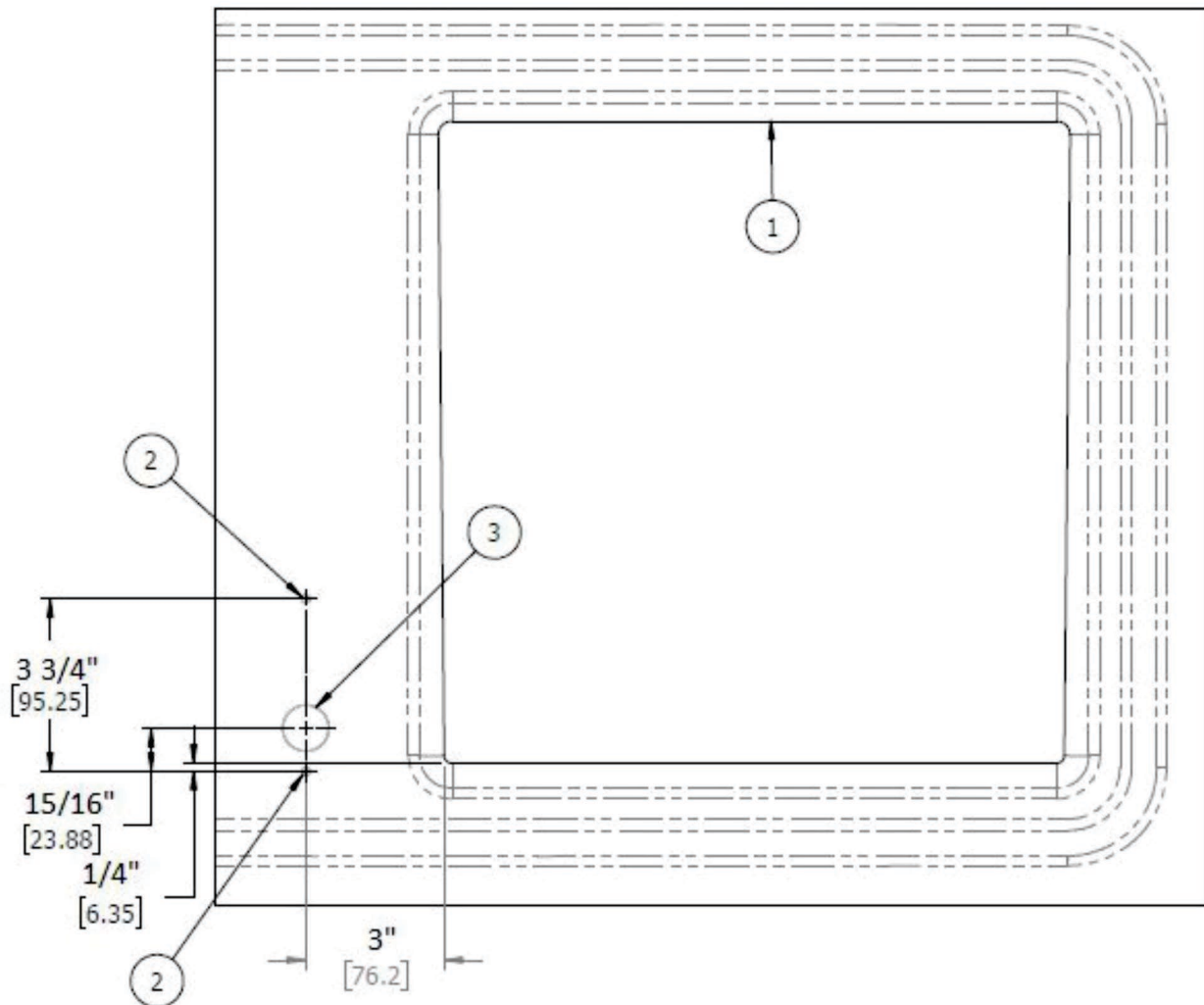

- 1 ground control turntable cover
- 2 keypad mounting holes, 11/64 inch / 4.4 mm drill bit
- 3 keypad harness hole, 1 inch / 25 mm step drill bit

