

# TECH-TIP

## Updating software on DC Scissors (Smartlink)

**Tools Needed:**

CAT5 Ethernet Cable  
PC or Laptop

**Model:**

**All Smartlink Scissor Lifts**

**Genie**  
A TEREX BRAND

**TECH-PRO**<sup>TM</sup>

SERVICE AND TECHNICAL TRAINING

# TECH-TIP

## Tech Tips Safety Rules



### **Danger**

Failure to obey the instructions and safety rules in the appropriate Operator's Manual and Service Manual for your machine will result in death or serious injury. Many of the hazards identified in the operator's manual are also safety hazards when maintenance and repair procedures are performed.

### **Do Not Perform Maintenance Unless:**

- You are trained and qualified to perform maintenance on this machine.
- You read, understand and obey:
  - manufacturer's instructions and safety rules
  - employer's safety rules and worksite regulations
  - applicable governmental regulations
- You have the appropriate tools, lifting equipment and a suitable workshop.

The information contained in this tech tip is a supplement to the service manual. Consult the appropriate service manual of your machine for safety rules and hazards.

# TECH-TIP

## Step 1

Turn the keyswitch to the GCON position. Pull out the red Emergency Stop buttons at the GCON and PCON.

Result: The display at the platform controls will show "CH."



## Step 2

Locate the diagnostic port on the side of the GCON (a).

Connect one end of the CAT5 Ethernet cable into the diagnostic port. Connect the other end into a PC or laptop.

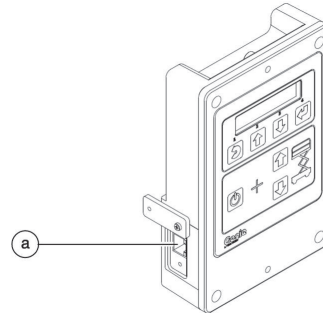

## Step 3

Launch a web browser such as Internet Explorer, Chrome, or Firefox on your PC or laptop. Type the IP address 139.168.11.1 into the web browser address bar and press enter.

Result: The following screen will be displayed.

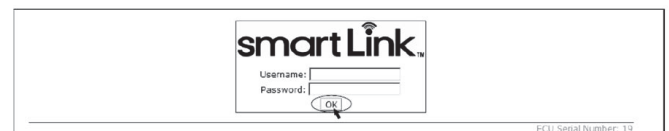

# TECH-TIP

## Step 4

Enter the following username and password then select OK.

Note: The username and password are case sensitive.

Username: smart.link  
Password: SL1000



## Step 5

Select the Software tab at the header bar.

## Step 6

Select the Choose File button and navigate to the downloaded Genie Flash File (.gff).

Note: Verify it is the correct flash file.

Select the Load Flash File button to verify the file is a .gff file.

## Step 7

Select the Reprogram Device(s) button to start the SCM software update.

Note: Do not turn off power while the ECM is being reprogrammed.

# TECH-TIP

## **Step 8**

Select the Run Application button to exit the software update mode.

## **Step 9**

Push the red Emergency Stop button and disconnect the CAT5 cable from the GCON.

## **Step 10**

Perform function test. Refer to the Operator's Manual on your machine.

Return the machine to service.