

Genie® S®-65 XC™ & S-65 TraX™

Specifications

Models	S-65 XC & S-65 TraX
Working height max. ⁽¹⁾	21.81 m
Working height max.(TraX) ⁽¹⁾	21.86 m
Platform height max.	19.81 m
Platform height max.(TraX)	19.86 m
Horizontal reach max.	16.51 m
Below ground reach	2.65 m
A Platform length (8 ft/6 ft)	0.91 m/0.76 m
B Platform width (8 ft/6 ft)	2.44 m/1.83 m
C Height - stowed (tires)	2.81 m
C Height - stowed (TraX)	2.87 m
D Length - stowed (tires)	9.76 m
D Length - stowed (TraX)	9.76 m
D Length - storage/transport (jib tucked under)	7.80 m
E Width (tires)	2.49 m
E Width (TraX)	2.48 m
F Wheelbase	2.49 m
G Ground clearance - center (tires)	0.41 m
G Ground clearance - center (TraX)	0.47 m
H Height under counterweight	1.17 m

Productivity

Lift capacity max. - unrestricted	300 kg
Lift capacity max. - restricted	454 kg
Number of Platform Occupants (restricted/unrestricted)	3/2
Platform rotation	160°
Jib length	1.52 m
Vertical jib rotation (up/down)	133°
Turntable rotation	360°
Turntable tailswing	1.41 m
Drive speed - stowed (tires)	4.8 km/h
Drive speed - stowed (TraX)	3.7 km/h
Drive speed - raised (tires)	0.3 m/s
Drive speed - raised (TraX)	0.2 m/s
Gradeability - stowed ⁽²⁾	45%
Tilt sensor activation (front to back/side to side)	7°/5°
Turning radius - inside/outside (tires)	3.20 m/5.40 m
Turning radius - inside/outside (TraX)	2.45 m/5.60 m
Tires	355/55D625
Track system - 4 points	TraX

Power

Power	Diesel
Hydraulic tank capacity	151 L
Fuel tank capacity	132 L

Weight⁽³⁾ and Floor Loading⁽⁴⁾

Weight (tires)	11,412 kg
Weight (TraX)	13,098 kg
Tire contact pressure	620 kPa
Track contact pressure	193 kPa
Occupied floor pressure (tires)	14.55 kPa
Occupied floor pressure (TraX)	4.82 kPa

Sound and Vibration Levels

Sound Pressure level (ground workstation)	85 dBA
Sound Pressure level (platform workstation)	75 dBA
Vibrations	< 2.5 m/s ²

(1) The metric equivalent of working height adds 2 m to platform height. The imperial equivalent adds 6 ft to platform height.

(2) Gradeability applies to driving on slopes and may vary depending on options and machine configurations. See operator's manual for details regarding slope ratings.

(3) Weight refers to standard configuration and may vary depending on options and/or country standards.

(4) Floor loading information is approximate and may vary depending on options and machine configurations. It should be used only with adequate safety factors.

Range of motion S-65 XC/S-65 TraX

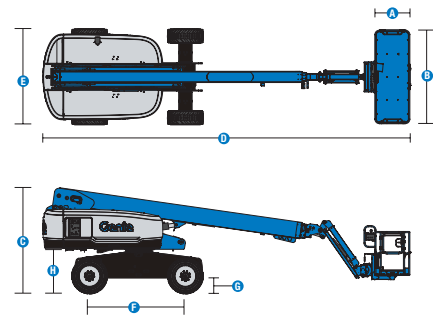
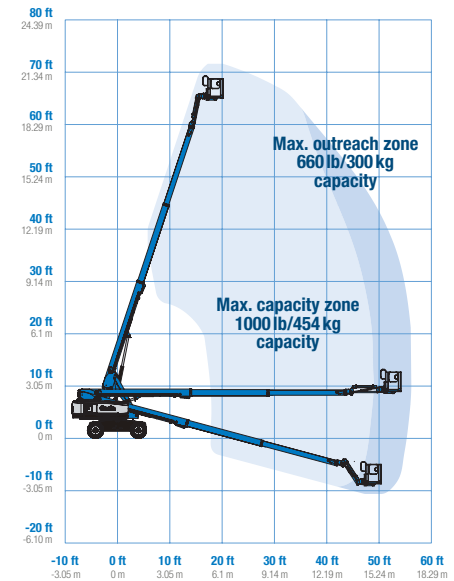

Genie® S®-65 XC™ & S-65 TraX™

SKU: Standard Model

- S-65 XC, 4WD*
- S-65 XC, T4i/Stage V, TraX*
- S-65 XC, TraX, Stage V, 60hp Turbo Deutz Diesel*

* Build to Order

Option availability		S	S+	BtO
Power	48 hp, 36 kW, Deutz D2011, Diesel, T4i/Stage IIIA			✓
	60 hp, 45 kW, Deutz TD2.2L, Turbo Diesel, Stage V (TraX only)			○
	Diesel catalytic scrubber muffler (T4i/Stage IIIA/CN III)			○
	LPS Fire protection rating			○
	Positive air shutdown system			○
	Anti-restart engine protection			✓
	Auto engine fault shutdown			✓
	In cylinder glow plug (diesel only)			✓
	Platform	6ft/1.83m dual-entry platform with side swing gate		
8ft/2.44m tri-entry platform with side swing gate				✓
Thumb rocker steering				✓
Air line to platform				○
Control box covers				○
Lift Guard Full Mesh panels				○
Lift Guard Half Mesh panels				○
Light Package: drive and work lights				○
Platform auxiliary top rail				○
Lift Power 3kW AC Generator, 110V/60Hz				○
Lift Power 3kW AC Generator, 220V/50Hz				○
660lb/300kg & 1000lb/454kg dual load capacity with automatic envelope control				✓
Drive enable system				✓
Horn				✓
Lift Guard Contact Alarm				✓
Lift Tools Work Tray				✓
Platform load sense system				✓
Proportional controls				✓
Self-leveling platform			✓	
Chassis	Lift Connect Telematics			○
	Telematics-ready			✓
	Lift Connect with Access Manager upgrade			○
	Eco32 biodegradable hydraulic oil			○
	Rough terrain, foam-filled tires			✓
	Rough terrain, foam-filled, non-marking tires			○
	TraX track drive system			○
	Deluxe hostile environment kit			○
	Hostile environment kit			○
	Chassis tilt lift and drive function cut-out			○
	2 speed wheel motors			✓
	Active oscillating axle			✓
	Alarm package: includes flashing beacon and travel alarm			✓
	Chassis tilt drive function cut-out			✓
	Descent, tilt and motion alarm			✓
Dual battery system			✓	
Hour meter			✓	
Hydraulic oil cooler			✓	
Positive traction drive			✓	
Tech Pro Link connector			✓	

- S Standard
- S+ Standard +
- BtO Build to Order
- ✓ Standard Features
- Options



Xtra Capacity



Rugged Terrainability



Lift Power



Genie Genuine Accessories⁽¹⁾

- Lift Tools Productivity Tools
- Tech Pro Link Handheld Device

(1) More accessories available from Genie Genuine Parts.

Product specifications are subject to change without notice or obligation. Photographs and/or drawings herein are for illustrative purposes only. Refer to the appropriate Operator's Manual for instructions on proper equipment use. Failure to follow instructions in the Operator's Manual may result in serious injury or death. The only warranty applicable to our equipment is the standard written warranty applicable to the particular product and sale and we make no other warranty, express or implied. Products and services listed may be trademarks, service marks or trade names of Terex Corporation and/or their subsidiaries in the USA and many other countries. Terex, Genie, Quality By Design, Xtra Capacity, Lift Power, Lift Guard, Lift Tools, Lift Connect and Tech Pro Link are registered trademarks of Terex Corporation or its subsidiaries.