

# Genie® GTH™ -5519

## Specifications

Models	GTH-5519	
Measurements	US	METRIC
Maximum lift height	18 ft 10 in	5.74 m
Maximum forward reach	11 ft 3 in	3.43 m
Reach at maximum height	1 ft 10 in	0.56 m
<b>A</b> Height, stowed	6 ft 6 in	1.98 m
<b>B</b> Length, stowed (without forks)	12 ft 3 in	3.73 m
Width	5 ft 11 in	1.80 m
<b>C</b> Wheelbase	7 ft 6 in	2.29 m
<b>D</b> Ground clearance, center	1 ft 2 in	0.36 m
<b>E</b> Ground clearance, axle	10 in	0.25 m
Fork cross section	1.6×4 in	40×100 mm

## Productivity

Maximum lift capacity	5,500 lb	2,495 kg
Lift capacity at maximum height	4,400 lb	1,996 kg
Lift capacity at maximum reach	1,900 lb	862 kg
Drive speed	15 mph	24 km/h
Draw bar pull	7,716 lb	3,500 kg
Turning radius, outside (4WS)	11 ft	3.35 m
Auxiliary hydraulic flow	17 gpm	64 lpm
Auxiliary hydraulic pressure	3,918 psi	270 bar
Tires, standard size	12×16.5 in, 10 ply	0.30×0.42 m, 10 ply

## Power

Power source	Deutz TCD 2.9	Deutz TCD 2.9
Electrical system voltage	12V	
Alternator	95 amp	
Battery	720 CCA 0°F (-18°C)	
Hydraulic tank capacity	18.5 gal	70L
Hydraulic system capacity (w/tank)	31.7 gal	120 L
Fuel tank capacity	15.8 gal	59.8 L

## Weight

Weight*	10,360 lb	4,700 kg
---------	-----------	----------

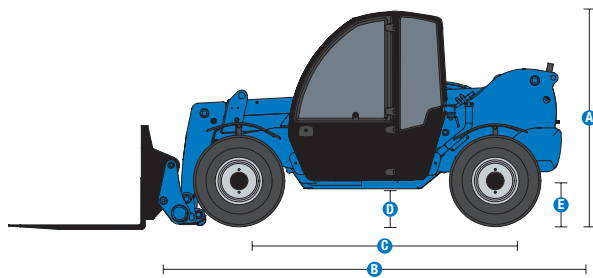

## Range of motion GTH-5519

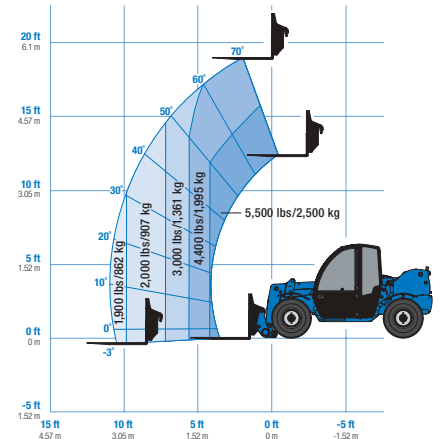

(1) Weight will vary depending on options and/or country standards.  
 (2) Load ratings vary depending on attachment.

# Genie® GTH™ -5519

## SKU: Standard Model

- **GTH55191AF0112:** GTH-5519, 74 hp, Open cab
- **GTH55191AF0152:** GTH-5519, 74 hp, Closed cab w/ heater
- **GTH55191AF0151:** GTH-5519, 74 hp, Closed cab w/ AC and heater

\* Build to Order

Option availability		S	S+	BtO
Cab	Cab ROPS/FOPS canopy*	✓	✓	✓
	Closed cab: Heater, defrost, wipers, washer, split door*	✓	✓	✓
	Closed cab: AC, heater, defrost, wipers, washer, split door*	✓	✓	✓
	Front and top glass		○	○
	Lift Guard White Noise Alarm		○	○
	Rear Proximity Alarm		○	○
	Fire extinguisher		○	○
	3in/7.6cm high visibility red retractable seat belt	✓	✓	✓
	Adjustable suspended seat	✓	✓	✓
	Backup alarm	✓	✓	✓
	Full gauge cluster with engine diagnostics	✓	✓	✓
	Fully proportional boom and auxiliary hydraulic controls	✓	✓	✓
	Machine level indicator	✓	✓	✓
	Mirrors - LH canopy mounted and RH chassis mounted	✓	✓	✓
	Multi-function joystick controller	✓	✓	✓
	Power steering	✓	✓	✓
RH steel mesh screen	✓	✓	✓	
Tilt steering wheel	✓	✓	✓	
Top glass	✓	✓	✓	
Chassis	74 hp, Deutz TCD 2.9, T4f, Side-mounted engine	✓	✓	✓
	Telematics-ready	✓	✓	✓
	Lift Connect Telematics		○	○
	Lift Connect with Access Manager upgrade		○	○
	Brick guard		○	○
	Cold weather package			○
	Electric oil pan heater			○
	Fenders set of four	✓	✓	✓
	Lojack stolen vehicle recovery system			○
	Positive air shutdown system			○
	Flashing Beacon		○	○
	Work lights: High output LED cab, boom, rear		○	○
	Road and work lights: High output LED front, cab, boom, rear		○	○
	Air-filled rough terrain tires	✓	✓	✓
	Air-filled turf tires		○	○
	Foam-filled rough terrain tires		○	○
	Non-marking, air-filled tires		○	○
	Non-marking, foam-filled tires		○	○
Solid rough terrain tires		○	○	
3-mode steering (2-wheel, 4-wheel and crab) with limited slip front differential	✓	✓	✓	
Cold start intake glow plugs	✓	✓	✓	
Full time 4WD with front limited slip differential (LSD)	✓	✓	✓	
Internal multiple wet disc brakes	✓	✓	✓	
Spring applied, hydraulic release parking brake	✓	✓	✓	
Variable speed hydrostatic drive	✓	✓	✓	
Boom	Genie manual Quick-Attach (QA) system	✓	✓	✓
	Genie hydraulic Quick-Attach (QA) system			○
	Auxiliary hydraulic circuit (18.5 GPM)	✓	✓	✓
	Boom angle indicator	✓	✓	✓
	Lifting shackle at boom tip	✓	✓	✓
	Self-leveling fork frame	✓	✓	✓

\*Choose from either Open cab or Closed cab/ Heater only or AC and Heater

- S Standard
- S+ Standard +
- BtO Build to Order
- ✓ Standard Features
- Options



Compact Footprint



Lift Shackle



Material Handling Attachments



### GTH Attachments

- Universal skid steer adapter (GTH-5519)
- QA Bucket .5cu.yd/0.38cu.m, 66in/1.67m (GTH-5519)
- QA Bucket 1cu.yd/0.76cu.m, 72in/1.82m (GTH-636, GTH-844)
- QA Bucket 1.5cu.yd/1.15cu.m, 96in/2.44m
- QA Carriage 48in/1.2m, 60in/1.5m, 72in/1.8m
- QA Fork positioner carriage 48in/1.2m
- QA Side shift carriage 48in/1.2m
- QA Side tilt rotating carr. 48in/1.2m, 60in/1.5m, 72in/1.8m
- QA Swing carriage 72in/1.8m
- QA Truss boom 8ft/2.44m Adjustable
- Cubing tines 48in (2x2x48in)/(.05x.05x1.2m) x 6
- Lumber forks 60in (1.75x7x60in)/(.04x.18x1.5m) x 2
- Pallet forks 48in (2x4x48in)/(.05x.1x1.2m) set of 2
- Pallet forks 60in (2x4x60in)/(.05x.1x1.5m) set of 2
- Pallet forks 72in (2x4x72in)/(.05x.1x1.8m) set of 2
- Pallet forks 96in (2x4x96in)/(.05x.1x2.4m) set of 2

Product specifications are subject to change without notice or obligation. Photographs and/or drawings herein are for illustrative purposes only. Refer to the appropriate Operator's Manual for instructions on proper equipment use. Failure to follow instructions in the Operator's Manual may result in serious injury or death. The only warranty applicable to our equipment is the standard written warranty applicable to the particular product and sale and we make no other warranty, express or implied. Products and services listed may be trademarks, service marks or trade names of Terex Corporation and/or their subsidiaries in the USA and many other countries. Terex, Genie, Quality By Design, Xtra Capacity, Lift Power, Lift Guard, Lift Tools, Lift Connect and Tech Pro Link are registered trademarks of Terex Corporation or its subsidiaries.